

## Does your surgical table need to be “remanufactured?”

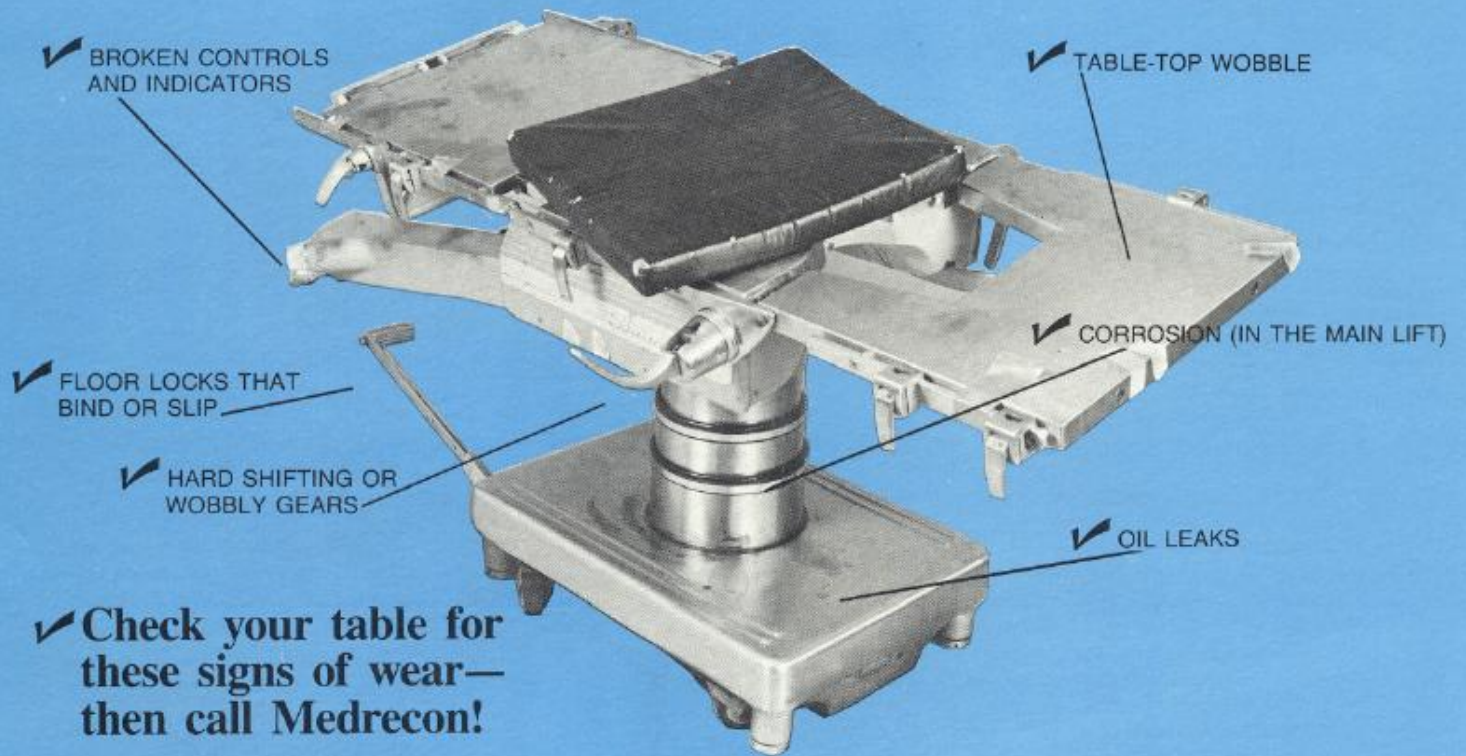

and dependability at  $\frac{1}{4}$  the cost?



Medrecon's unique, cost-effective *remanufacturing* process restores surgical, cysto, orthopedic, exam, and delivery tables (all makes and models) to "like-new" condition or better—we guarantee it.

**For 17 years, Medrecon has been the leader in restoring surgical tables. Here are some of the questions people most frequently ask about our unique and special service.**

**Q:** You say Medrecon "remanufactures" tables. What does that mean?

**A:** Remanufacturing is where the wearing parts in every system are replaced, and all non-wearing surfaces are refinished (rechromed, polished, or painted). During the remanufacturing process, your table is completely taken apart and rebuilt—restoring the table to its original working condition, appearance, and dependability. Our free brochure (see coupon below) explains the process in detail.

**Q:** Isn't remanufacturing my existing table just a stop-gap measure?

**A:** No, it's not. The Medrecon remanufacturing process is a permanent solution, not a temporary one. Once remanufactured, your table will have the reliability, performance characteristics, and trouble-free life expectancy it possessed when it was new. We guarantee it. And for the price of buying a new table, we can remanufacture **four** of your existing tables!

What's more, the remanufacturing process can, at your option, upgrade your table to include new features added by the manufacturer since the table was originally purchased—such as improved floor-locks, X-ray capability, and C-arm capability. Plus, you will receive a free set of new conductive cushions with every table we sell or rebuild. As a result, a Medrecon remanufactured table is truly equal to a new table in all regards.

**Q:** Why is Medrecon best qualified to remanufacture my table?

**A:** Medrecon is the country's oldest and largest surgical table remanufacturer. We have 17 years experience rebuilding tables for more than 500 hospitals and surgi-centers nationwide. What's more, Medrecon offers you:

- an unconditional one-year guarantee on parts and labor
- a total commitment to quality, dependability, and customer service
- references from hospital and surgical centers we have served in your area (available upon request).

**Q:** How can my OR continue to operate while you rebuild my table?

**A:** We can provide you with a free loaner table. Or, you may choose to take advantage of our **rebuilt-exchange**, where you trade in your worn-out table for a completely remanufactured table of the same make and model. We also sell and lease remanufactured tables and stock a full inventory of table parts and accessories. We handle tables from **all** major manufacturers including Amsco, Shampaine, Skytron, Siemens, Castle, Radi-op, and Ritter.

For more information on Medrecon's money-saving table remanufacturing services, call us toll-free...  
**800-526-4323** in New Jersey, **201-789-2050**



**YES,** I'd like to know more. Please send me a **free brochure** describing Medrecon's unique money-saving table remanufacturing service.

**CALL ME**—I need a price quotation on remanufacturing a table

Manufacturer \_\_\_\_\_ Model \_\_\_\_\_

Name \_\_\_\_\_ Title \_\_\_\_\_

Facility \_\_\_\_\_ Phone \_\_\_\_\_

Address \_\_\_\_\_

City \_\_\_\_\_ State \_\_\_\_\_ Zip \_\_\_\_\_

Approximate number of tables at this facility \_\_\_\_\_

Other people at this facility who should receive a **free brochure** on Medrecon's money-saving table remanufacturing service:

Name \_\_\_\_\_

Title \_\_\_\_\_

Name \_\_\_\_\_

Title \_\_\_\_\_

Send for it—  
**FREE!**





NO POSTAGE  
NECESSARY  
IF MAILED  
IN THE  
UNITED STATES

**BUSINESS REPLY MAIL**  
FIRST CLASS MAIL      PERMIT NO. 1      GARWOOD, NJ 07027

POSTAGE WILL BE PAID BY ADDRESSEE

**MEDRECON, INC.**  
257 South Avenue  
Garwood, NJ 07027-9804





# MEDRECON, INC.

257 South Avenue  
Garwood, NJ 07027

BULK RATE  
U.S. Postage  
**PAID**  
MEDRECON  
INC.

## Hospitals and surgi-centers:

Is it worth spending \$15,000 to \$25,000  
on a new surgical table . . .  
. . . when you can get Medrecon quality  
and dependability at  $\frac{1}{4}$  the cost?